

Design Data	
Commutation	Brushed
Direction of rotation	Bi-directional
Bearing type	A:Ball - B:Sleeve

Performance data		
Rated voltage [V]	$U_N$	24
Nominal torque [Nm]	$M_N$	3.00
No-load speed [ $\text{min}^{-1}$ ]	$n_0$	195.0
Nominal power [W]	$P_N$	52.5
Nominal current [A]	$I_N$	5.0
Nominal force [kN]	$F_N$	0.00
Duty cycle	s1	

Sensor data	
Pulses	207
Output channels	1

Other data	
Gear ratio	53/2
Gear wheel material	plastic
Suppression components	$6\mu\text{H}$ , $1\text{nF}$
Enclosure class	IP 30
Weight [kg]	1.210

Remarks: d = for thread-forming screw M6 DIN ISO 965-2

### Characteristic curves

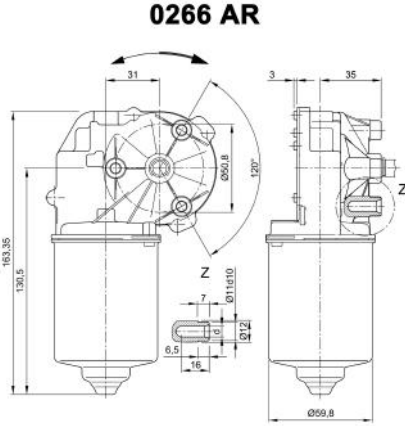

### Motor picture

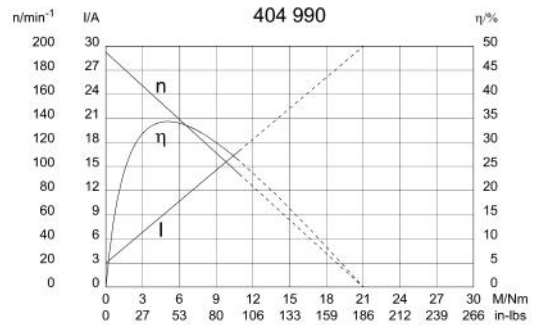

### Output shaft drawing (W), Wiring diagrams (S) and Connector layout (K)

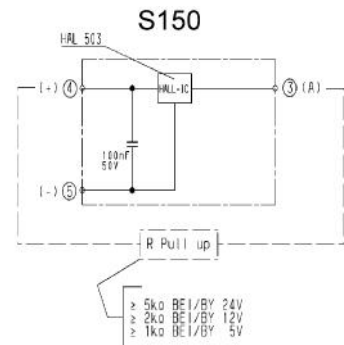
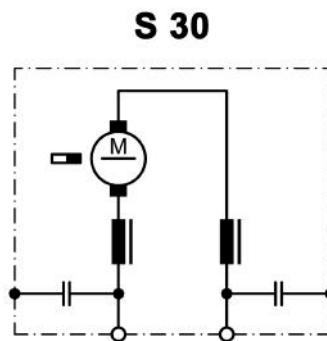
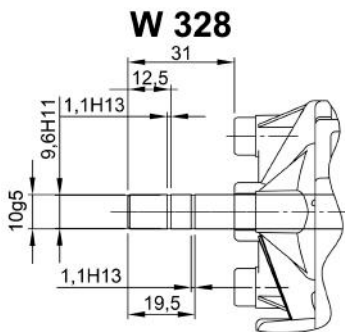

**Output shaft drawing (W), Wiring diagrams (S) and Connector layout (K)**

**K 320**

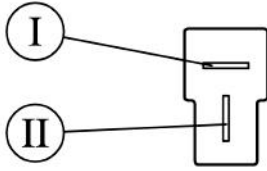

Fiat plug (DIN 46244) 6,3x0,8 mating with receptacle housing part#180907, drwg# C-180907 & Receptacles for tabs, conductor cross section 0,5-1,5 sqmm (20-18AWG) part# 925603-x, drwg# 925603 [www.tycoelectronics.com](http://www.tycoelectronics.com)

**K 326**

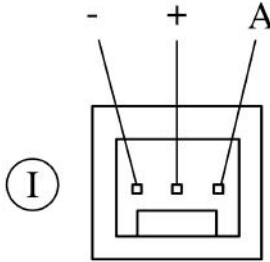

MAS-CON solder tail MLAS 100-3435 mating with end connector CE 100F-22-xx-x-x or CEP 100F-22-xx-x-x

**K 321**

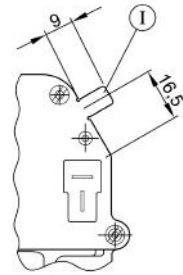

I Ground connection  
 Blade terminal 6.3 x 0.8 DIN 46 244

**Notes**

---



---



---



---



---



---



---



---



---



---



---



---



---



---



---